

# Hypertherm® powermax65®

## H65 and H65s hand torch consumables

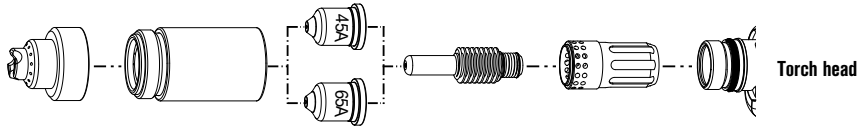

### Drag-cutting consumables



	Shield	Retaining cap	Nozzle	Electrode	Swirl ring
45 A	220818*	220854	220941*	220842*	220857
65 A	220818*	220854	220819*	220842*	220857

### Gouging consumables

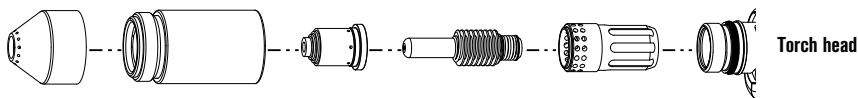

	Shield	Retaining cap	Nozzle	Electrode	Swirl ring
65 A	220798	220854	220797*	220842*	220857

### FineCut consumables

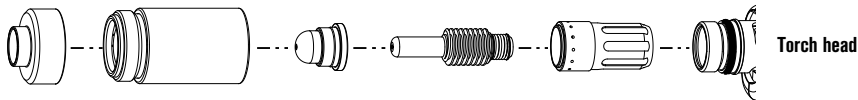

	Shield/Deflector	Retaining cap	Nozzle	Electrode	Swirl ring
45 A	220931	220854	220930*	220842*	220947



**Duramax™ series**

All-in-one and FineCut kits available. Visit [www.hypertherm.com/consumablekits](http://www.hypertherm.com/consumablekits) or see pages 87 – 88 for options.

\* Consumables available in multiple packaging options, see page 87 for bulk package information.

Hypertherm, Powermax, FineCut, FastConnect, Spring Start and Smart Sense are trademarks of Hypertherm, Inc. and may be registered in the United States and/or other countries.

#### TECHNOLOGIES

**FineCut®**  
**Dielectric shield**  
**FastConnect™**  
**Vented shield**  
**Conical Flow**  
**Spring Start™**  
**Smart Sense™**

# powermax65<sup>®</sup>

## H65, H65s hand torch assembly

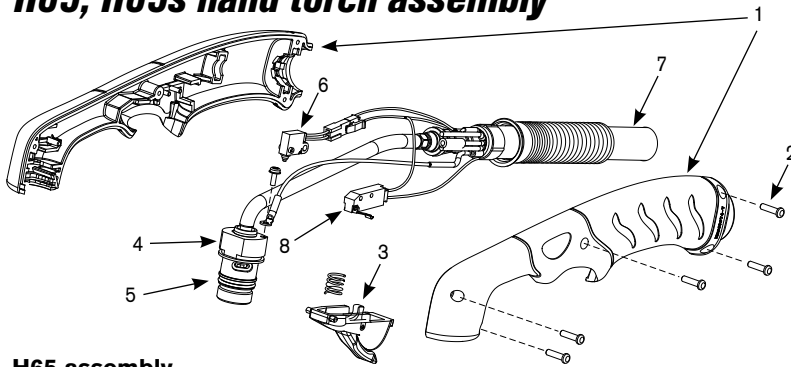

### H65 assembly

Part number	Description
083247*	H65 Hand torch assembly with 25' (7.6 m) lead
083248*	H65 Hand torch assembly with 50' (15.2 m) lead
083249*	H65 Hand torch assembly with 75' (22.9 m) lead
1. 228717	Kit: H65/H85 Torch handle replacement
2. 075714	Handle screws, #4 x 1/2 slotted TORX pan head, S/B
3. 228721	Kit: H65/H85/H65s/H85s (spring and trigger assembly)
4. 228714	Kit: H65/H85 Torch main body replacement
5. 058519	O-ring
6. 228719	Kit: H65/H85 Cap-sensor switch replacement
7. 228723	Kit: H65/H85 Torch lead replacement, 25' (7.6 m)
7. 228724	Kit: H65/H85 Torch lead replacement, 50' (15.2 m)
7. 228725	Kit: H65/H85 Torch lead replacement, 75' (22.9 m)
8. 005252	Trigger start switch
223125†	Kit: 65 A Work lead with hand clamp, 25' (7.5 m) (not pictured)

\*Assembly includes one set of drag-cutting consumables

†Other work lead options available

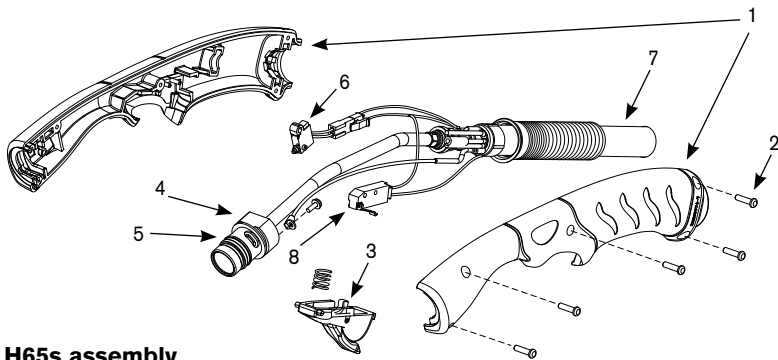

### H65s assembly

Part number	Description
083251*	H65s Hand torch assembly with 25' (7.6 m) lead
083252*	H65s Hand torch assembly with 50' (15.2 m) lead
083253*	H65s Hand torch assembly with 75' (22.9 m) lead
1. 228718	Kit: H65s/H85s Torch handle replacement
2. 075714	Handle screws, #4 x 1/2 slotted TORX pan head, S/B
3. 228721	Kit: H65/H85/H65s/H85s (spring and trigger assembly)
4. 228715	Kit: H65s/H85s Torch main body replacement
5. 058519	O-ring
6. 228109	Kit: H65s/H85s Cap-sensor switch replacement
7. 228727	Kit: H65s/H85s Torch lead replacement, 25' (7.6 m)
7. 228728	Kit: H65s/H85s Torch lead replacement, 50' (15.2 m)
7. 228729	Kit: H65s/H85s Torch lead replacement, 75' (22.9 m)
8. 005252	Trigger start switch
223125†	Kit: 65 A Work lead with hand clamp, 25' (7.5 m)

\*Assembly includes one set of drag-cutting consumables

†Other work lead options available

Hypertherm, Powermax, FineCut, FastConnect, Spring Start and Smart Sense are trademarks of Hypertherm, Inc. and may be registered in the United States and/or other countries.

# Hypertherm® powermax65®

## M65 and M65m machine torch consumables



### Mechanized consumables

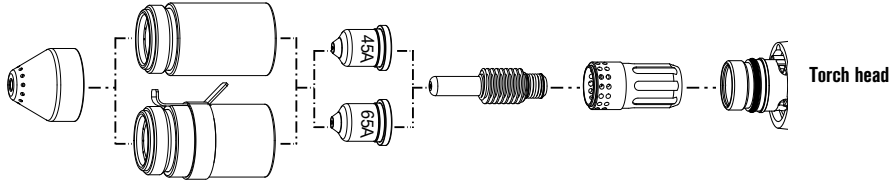

	Shield	Retaining cap	Nozzle	Electrode	Swirl ring
45 A	220817*	220854	220941*	220842*	220857
65 A	220817*	220854	220819*	220842*	220857
Ohmic		220953			

### Unshielded consumables

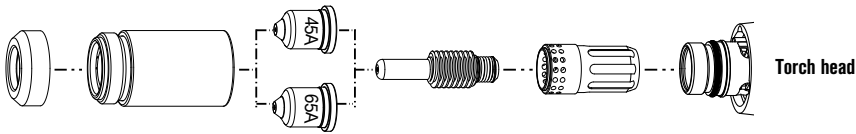

	Shield/Deflector	Retaining cap	Nozzle	Electrode	Swirl ring
45 A	220955	220854	220941*	220842*	220857
65 A	220955	220854	220819*	220842*	220857

### Gouging consumables

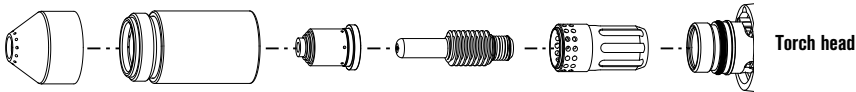

	Shield	Retaining cap	Nozzle	Electrode	Swirl ring
65 A	220798	220854	220797*	220842*	220857

### FineCut consumables

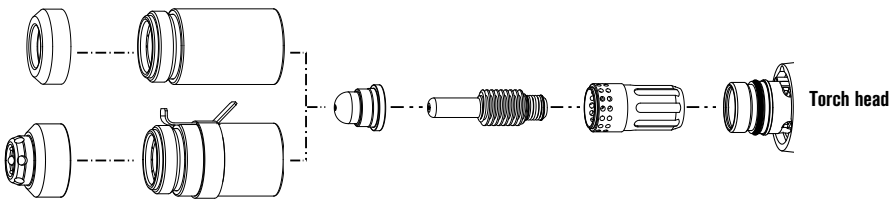

	Shield/Deflector	Retaining cap	Nozzle	Electrode	Swirl ring
45 A	220955	220854	220930*	220842*	220857
Ohmic	220948	220953			



### Duramax™ series

All-in-one and FineCut kits available. Visit [www.hypertherm.com/consumablekits](http://www.hypertherm.com/consumablekits) or see pages 87 – 88 for options.

\* Consumables available in multiple packaging options, see page 87 for bulk package information.

### TECHNOLOGIES

**FineCut®**  
**Dielectric shield**  
**FastConnect™**  
**Vented shield**  
**Conical Flow™**  
**Spring Start™**  
**Smart Sense™**

Hypertherm, Powermax, FineCut, FastConnect, Conical Flow, Spring Start and Smart Sense are trademarks of Hypertherm, Inc. and may be registered in the United States and/or other countries.

# powermax65<sup>®</sup>

## M65 and M65m machine torch assembly

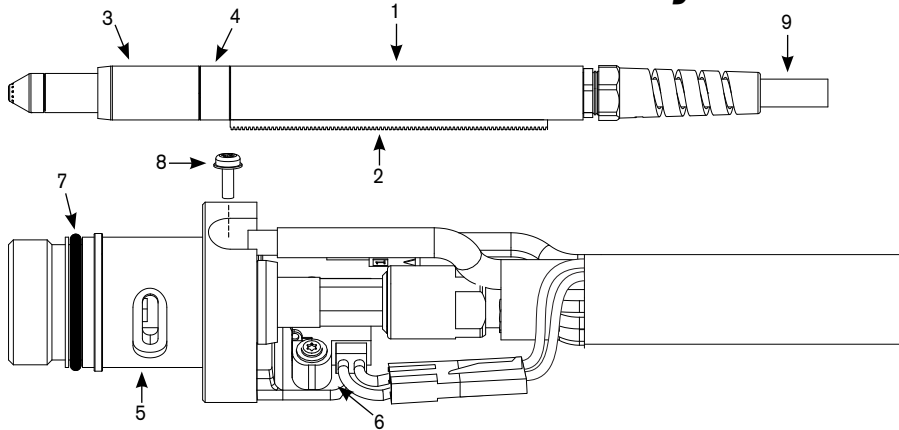

### M65 assembly

Part number	Description
083254*	M65 Machine torch assembly with 15' (4.6 m) lead
083255*	M65 Machine torch assembly with 25' (7.6 m) lead
083256*	M65 Machine torch assembly with 35' (10.7 m) lead
083257*	M65 Machine torch assembly with 50' (15.2 m) lead
083258*	M65 Machine torch assembly with 75' (22.9 m) lead
1. 228737	Kit: M65/M85 positioning sleeve
2. 228738	Kit: M65/M85 removable gear rack
3. 228735	Kit: M65/M65m/M85/M85m front mounting sleeve
4. 228736	Kit: M65/M65m/M85/M85m adapter ring (coupler)
5. 228716	Kit: M65/M65m/M85/M85m torch main body replacement
6. 228720	Kit: Cap-sensor switch replacement
7. 058519	O-ring
8. 075504	Pilot terminal screw
9. 228730	Kit: M65/M65m/M85/M85m torch lead replacement, 15' (4.6 m)
9. 228731	Kit: M65/M65m/M85/M85m torch lead replacement, 25' (7.6 m)
9. 228732	Kit: M65/M65m/M85/M85m torch lead replacement, 35' (10. m)
9. 228733	Kit: M65/M65m/M85/M85m torch lead replacement, 50' (15.2 m)
9. 228734	Kit: M65/M65m/M85/M85m torch lead replacement, 75' (22.9 m)
128650	Remote start pendant for machine torch, 25' (7.63 m)
128651	Remote start pendant for machine torch, 50' (15.24 m)
128652	Remote start pendant for machine torch, 75' (22.86 m)
223125†	Kit: 65 A Work lead with hand clamp, 25' (7.5 m)

\*Assembly includes one set of mechanized consumables

†Other work lead options available

### M65m assembly

Part number	Description
083259*	M65m Mini-machine torch assembly with 15' (4.6 m) lead
083260*	M65m Mini-machine torch assembly with 25' (7.6 m) lead
083261*	M65m Mini-machine torch assembly with 35' (10.7 m) lead
083262*	M65m Mini-machine torch assembly with 50' (15.2 m) lead
083263*	M65m Mini-machine torch assembly with 75' (22.9 m) lead
3. 228735	Kit: M65/M65m/M85/M85m front mounting sleeve
4. 228736	Kit: M65/M65m/M85/M85m adapter ring (coupler)
5. 228716	Kit: M65/M65m/M85/M85m torch main body replacement
6. 228720	Kit: Cap-sensor switch replacement
7. 058519	O-ring
8. 075504	Pilot terminal screw
9. 228730	Kit: M65/M65m/M85/M85m torch lead replacement, 15' (4.6 m)
9. 228731	Kit: M65/M65m/M85/M85m torch lead replacement, 25' (7.6 m)
9. 228732	Kit: M65/M65m/M85/M85m torch lead replacement, 35' (10.7 m)
9. 228733	Kit: M65/M65m/M85/M85m torch lead replacement, 50' (15.2 m)
9. 228734	Kit: M65/M65m/M85/M85m torch lead replacement, 75' (22.9 m)
128650	Remote start pendant for machine torch, 25' (7.63 m)
128651	Remote start pendant for machine torch, 50' (15.24 m)
128652	Remote start pendant for machine torch, 75' (22.86 m)
223125†	Kit: 65 A Work lead with hand clamp, 25' (7.5 m)

\*Assembly includes one set of mechanized consumables

†Other work lead options available

