

Hypertherm®

powermax600

PAC123T hand torch consumables



Shielded consumables

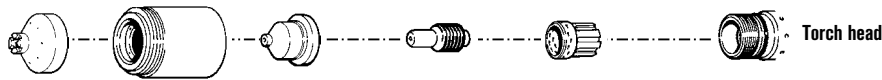

Shield	Retaining cap	Nozzle	Electrode	Swirl ring	Torch head
120828	120600	120826	120573	120576	

Unshielded* consumables

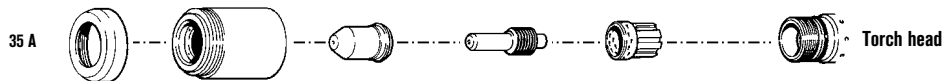

35 A	Deflector	Retaining cap	Nozzle	Electrode	Swirl ring	Torch head
35 A	120303	120600	120606	120574	120576	

Gouging consumables

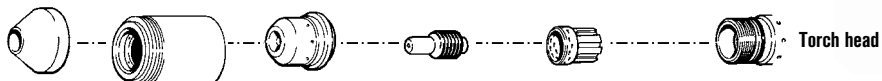

Shield	Retaining cap	Nozzle	Electrode	Swirl ring	Torch head
120608	120600	120831	120573	120576	

FineCut consumables

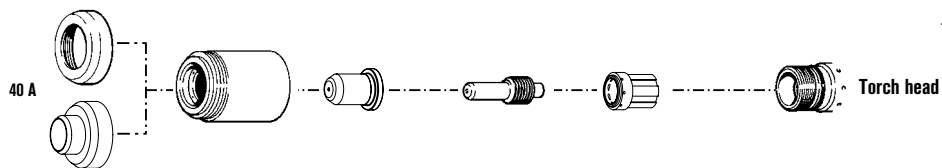

Deflector	Retaining cap	Nozzle	Electrode	Swirl ring	Torch head
40 A 120303	120600	220330	120574	220332	
40 A CE** 220326	120600	220330	120574	220332	

Note:

The nozzles and swirl rings shown must be used as a set.

* In countries following CE standards, unshielded consumables may only be used in mechanized torch applications.

** CE shield for use in countries requiring CE, CCC, GOST marks.

Hypertherm, Powermax, PAC, FineCut, Coaxial-assist and HyLife are trademarks of Hypertherm, Inc. and may be registered in the United States and/or other countries.



TECHNOLOGIES

FineCut®
Coaxial-assist™ jet
Vented shield
Spiral groove
HyLife®

powermax600

PAC123T hand torch assembly

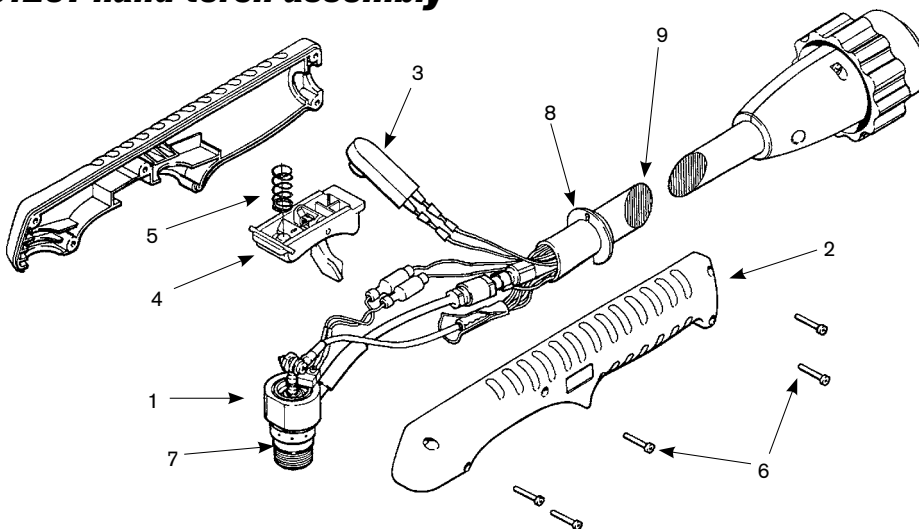

Assembly – torch with quick disconnects only for use with 208-240V and 480V systems

Part number	Description
086023*	PAC123T hand torch assembly with QD 15' (4.6 m) leads
086024*	PAC123T hand torch assembly with QD 25' (7.6 m) leads
086025*	PAC123T hand torch assembly with QD 50' (15.2 m) leads
083219*	Test torch with 6' (1.8 m) leads
9. 129599	Torch leads with QD, 15' (4.6 m)
9. 129600	Torch leads with QD, 25' (7.6 m)
9. 129601	Torch leads with QD, 50' (15.2 m)
123375	Work lead with clamp, 15' (4.6 m)
128379	Work lead with clamp, 50' (15.2 m)

Assembly – torch without quick disconnects only for use with 230V and 400V systems

Part number	Description
086001*	PAC123T hand torch assembly, without QD 15' (4.6 m) leads
086002*	PAC123T hand torch assembly, without QD 25' (7.6 m) leads
086003*	PAC123T hand torch assembly, without QD 50' (15.2 m) leads
083219*	Test torch with 6' (1.8 m) leads
9. 129475	Torch leads, without QD, 15' (4.6 m)
9. 129476	Torch leads, without QD, 25' (7.6 m)
9. 129477	Torch leads, without QD, 50' (15.2 m)
1. 120570	Torch main body with switch
2. 001288	Handle (includes both halves)
3. 128377	Kit: Switch repair
4. 002244	Safety trigger assembly
5. 027254	Trigger spring
6. 075339	Screw, #4 x 1/2" (five required)
7. 044016	O-ring, Buna – N 90 Duro
8. 004764	Retaining ring, Gutcha
123375	Work lead with clamp, 15' (4.6 m)
128379	Work lead with clamp, 50' (15.2 m)

* Assembly includes consumables



Hypertherm®

powermax600

PAC123M machine torch consumables



Shielded consumables

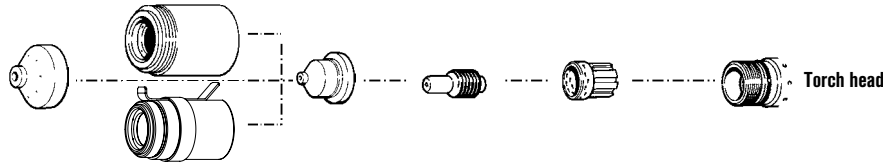

	Shield	Retaining cap	Nozzle	Electrode	Swirl ring
	120827	120600	120826	120573	120576
Ohmic		120964			

Unshielded consumables

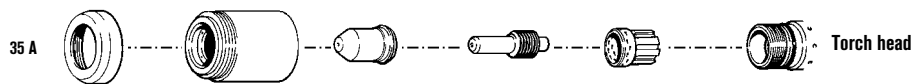

	Deflector	Retaining cap	Nozzle	Electrode	Swirl ring
35 A	120303	120600	120606	120574	120576

Gouging consumables

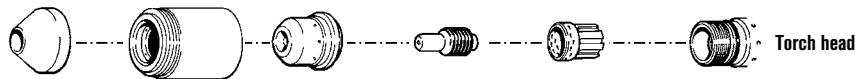

	Shield	Retaining cap	Nozzle	Electrode	Swirl ring
	120608	120600	120831	120573	120576

FineCut consumables

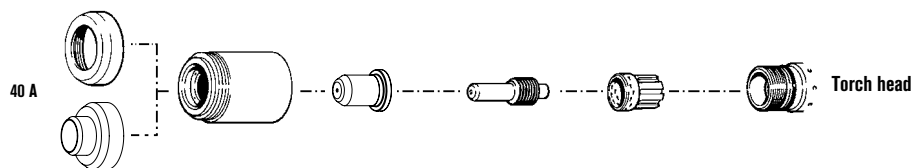

	Deflector	Retaining cap	Nozzle	Electrode	Swirl ring
40 A	120303	120600	220330	120574	120576
40 A CE	220326	120600	220330	120574	120576

Note:

The nozzles and swirl rings shown must be used as a set.



TECHNOLOGIES

FineCut®
Coaxial-assist™ jet
Vented shield
Spiral groove
HyLife®

Hypertherm, Powermax, PAC, FineCut, Coaxial-assist and HyLife are trademarks of Hypertherm, Inc. and may be registered in the United States and/or other countries.

powermax600

PAC123M torch assembly

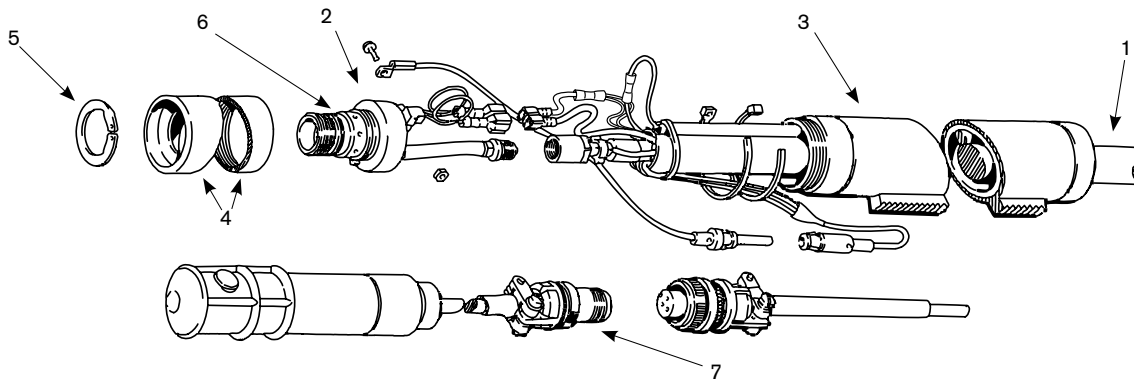

Assembly – torch with quick disconnects only for use with 208-240V and 480V systems

Part number	Description
086026*	PAC123M machine torch assembly with QD 15' (4.6 m) leads (with pigtail)
086027*	PAC123M machine torch assembly with QD 25' (7.6 m) leads (with pigtail)
086029*	PAC123M machine torch assembly with QD 50' (15.2 m) leads (with pigtail)
083219*	Test torch with 6' (1.8 m) leads
1. 128572	Torch leads with QD, 15' (4.6 m) (with pigtail)
1. 128573	Torch leads with QD, 25' (7.6 m) (with pigtail)
1. 128574	Torch leads with QD, 50' (15.2 m) (with pigtail)
123375	Work lead with clamp, 15' (4.6 m)
128379	Work lead with clamp, 50' (15.2 m)

Assembly – torch without quick disconnects only for use with 230V and 400V systems

Part number	Description
086004*	PAC123M machine torch assembly, without QD 15' (4.6 m) leads (with pigtail)
086005*	PAC123M machine torch assembly, without QD 25' (7.6 m) leads (with pigtail)
086006*	PAC123M machine torch assembly, without QD 50' (15.2 m) leads (with pigtail)
083219*	Test torch with 6' (1.8 m) leads
1. 128374	Torch leads, without QD, 15' (4.6 m) (with pigtail)
1. 128375	Torch leads, without QD, 25' (7.6 m) (with pigtail)
1. 128376	Torch leads, without QD, 50' (15.2 m) (with pigtail)
2. 120583	Torch main body with switch
3. 020620	Torch position sleeve
4. 120613	Torch sleeve
5. 027599	Snap ring
6. 044016	O-ring, Buna – N 90 Duro
7. 028714	On/Off pendant, 25' (7.6 m)
7. 128061	On/Off pendant, 50' (15.2 m)
7. 128062	On/Off pendant, 75' (22.9 m)
029257	Torch leads, 25' (7.6 m)
128379	Work lead with clamp, 50' (15.2 m)

* Assembly includes consumables

