

# Hypertherm®

## powermax800

### PAC121TS/125T hand torch consumables

#### Shielded consumables

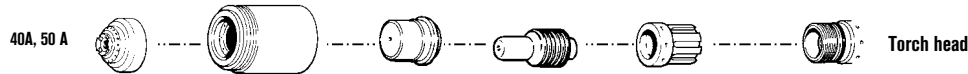

	Shield	Retaining cap	Nozzle	Electrode	Swirl ring
40 A	120601	120600	120438	120573	020361
50 A	120601	120600	120282	120573	020361

#### Unshielded\* consumables

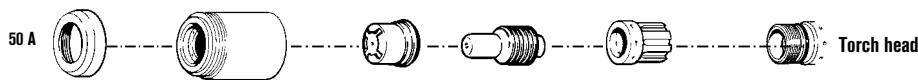

	Deflector	Retaining cap	Nozzle	Electrode	Swirl ring
50 A	120303	120600	020395	120573	020361

#### Extended consumables

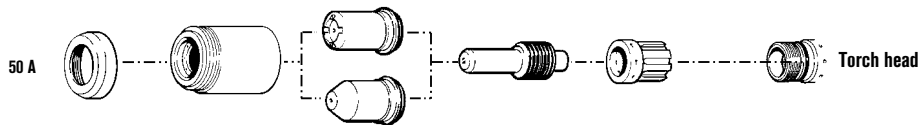

	Deflector	Retaining cap	Nozzle	Electrode	Swirl ring
50 A	120303	120600	120304	120574	020361
Pipe saddle	120303	120600	120305	120574	020361

#### Gouging consumables

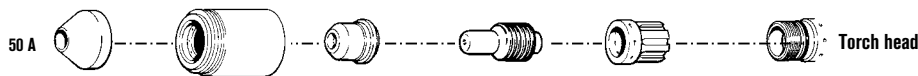

	Shield	Retaining cap	Nozzle	Electrode	Swirl ring
50 A	120608	120600	120281	120573	020361

#### FineCut consumables

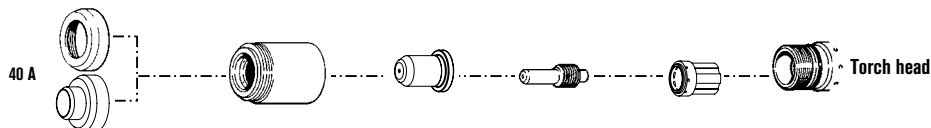

	Deflector	Retaining cap	Nozzle	Electrode	Swirl ring
40 A	120303	120600	220330	120574	220332
40 A CE**	220326	120600	220330	120574	220332

**Notes:**

The nozzles and swirl rings shown must be used as a set.

A label located on the torch handle indicates whether the torch is a PAC121TS or PAC125T.

\* In countries following CE standards, unshielded consumables may only be used in mechanized torch applications.

\*\* CE shield for use in countries requiring CE, CCC, GOST marks.

Hypertherm, Powermax, PAC and FineCut are trademarks of Hypertherm, Inc. and may be registered in the United States and/or other countries.



**For improved performance, retrofit with the RT60 torch (see page 75).**

**TECHNOLOGIES**

**FineCut®**  
**Spiral groove**  
**Vented shield**

# powermax800

## PAC121TS/125T hand torch assembly

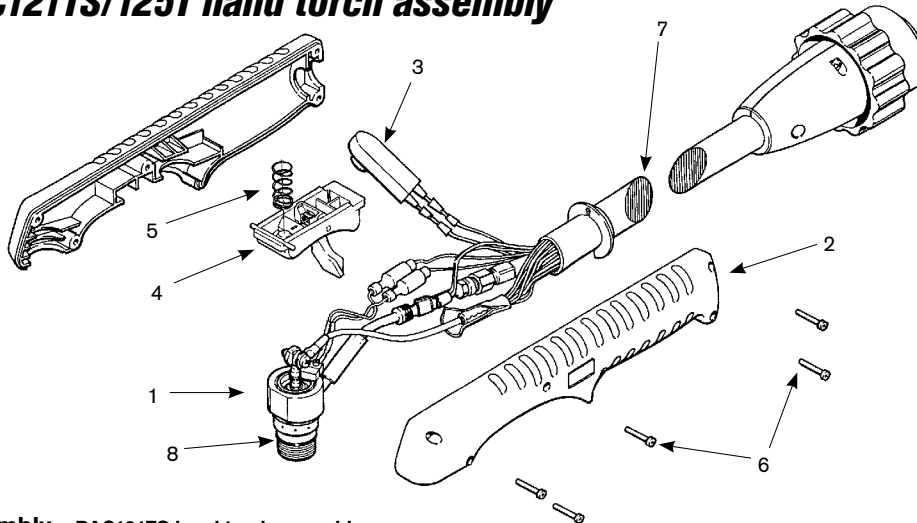

### Assembly – PAC121TS hand torch assembly

Part number	Description
083130*	PAC125T/Powermax800 hand torch assembly with 25' (7.6 m) leads
083131*	PAC125T/Powermax800 hand torch assembly with 50' (15.2 m) leads
083219*	Test torch with 6' (1.8 m) leads
1. 120556	Torch main body with switch
2. 001288	Handle (includes both halves)
3. 128284	Switch, torch pushbutton
4. 002244	Safety trigger assembly
5. 027254	Trigger spring
6. 075340	Screw, #4 x 5/8" (five required)
7. 129001	PAC121TS torch leads, 25' (7.6 m)
7. 129002	PAC121TS torch leads, 50' (15.2 m)
8. 044016	O-ring, Buna – N 90 Duro
023922	Work lead with clamp, 20' (6.1 m)
028907	Work lead with clamp, 50' (15.2 m)

### Assembly – PAC125T hand torch assembly

Part number	Description
083130*	PAC125T/Powermax800 hand torch assembly with 25' (7.6 m) leads
083131*	PAC125T/Powermax800 hand torch assembly with 50' (15.2 m) leads
083219*	Test torch with 6' (1.8 m) leads
1. 120570	Torch main body with switch
2. 001288	Handle (includes both halves)
3. 128284	Switch, torch pushbutton
4. 002244	Safety trigger assembly
5. 027254	Trigger spring
6. 075340	Screw, #4 x 5/8" (five required)
7. 129352	PAC125T torch leads, 25' (7.6 m)
7. 129353	PAC125T torch leads, 50' (15.2 m)
8. 044016	O-ring, Buna – N 90 Duro
023922	Work lead with clamp, 20' (6.1 m)
028907	Work lead with clamp, 50' (15.2 m)

\*Assembly includes consumables

#### Note:

A label located on the torch handle indicates whether the torch is a PAC121TS or PAC125T.

Hypertherm, Powermax, PAC and FineCut are trademarks of Hypertherm, Inc. and may be registered in the United States and/or other countries.



# Hypertherm®

## powermax800

### PAC121M/125M machine torch consumables

#### Shielded consumables

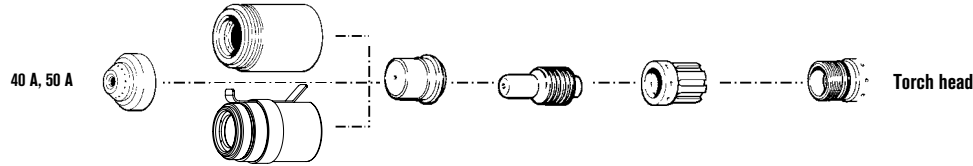

	Shield	Retaining cap	Nozzle	Electrode	Swirl ring
40 A	120602	120600	120438	120573	020361
50 A	120602	120600	120282	120573	020361
Ohmic		120964			

#### Unshielded consumables

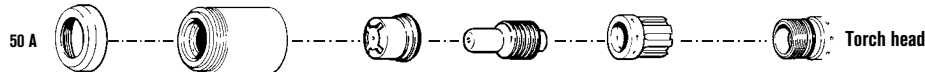

	Deflector	Retaining cap	Nozzle	Electrode	Swirl ring
50 A	120303	120600	020395	120573	020361

#### Extended consumables

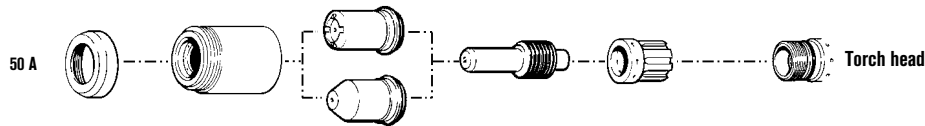

	Deflector	Retaining cap	Nozzle	Electrode	Swirl ring
50 A	120303	120600	120304	120574	020361
Pipe saddle	120303	120600	120305	120574	020361

#### Gouging consumables

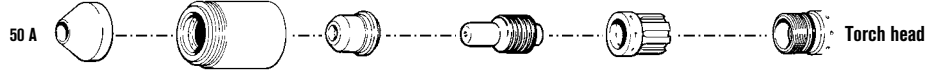

	Shield	Retaining cap	Nozzle	Electrode	Swirl ring
50 A	120608	120600	120281	120573	020361

#### FineCut consumables

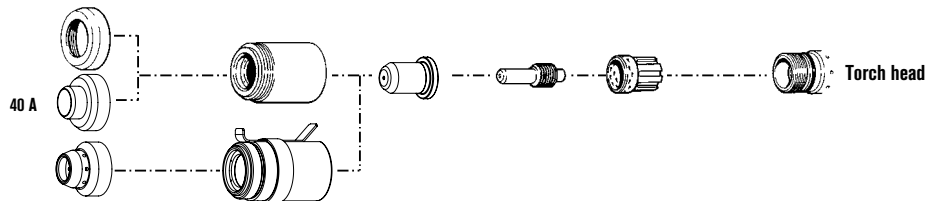

	Shield / Deflector	Retaining cap	Nozzle	Electrode	Swirl ring
40 A	120303	120600	220330	120574	120576
40 A CE	220326	120600	220330	120574	120576
Ohmic	220403	120964			

#### Notes:

The nozzles and swirl rings shown must be used as a set.

A label located on the torch handle indicates whether the torch is a PAC121TS or PAC125T.



#### TECHNOLOGIES

**FineCut®**  
**Spiral groove**  
**Vented shield**

## PAC121M/PAC125M machine torch assembly

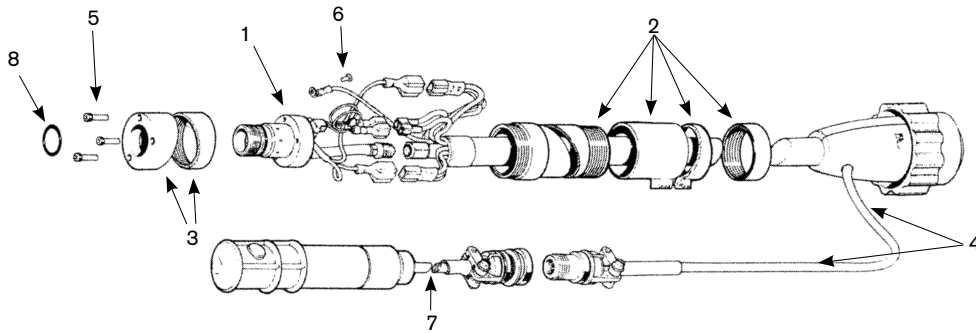

### Assembly – PAC121M machine torch assembly

Part number	Description
083219*	Test torch with 6' (1.8 m) leads
1. 120558	Torch main body with switch
2. 020620	Torch position sleeve
3. 020559	Torch sleeve
4. 028923	Torch lead with pigtail, 14' (4.3 m)
4. 028918	Torch lead with pigtail, 25' (7.6 m)
4. 028926	Torch lead with pigtail, 35' (10.7 m)
4. 028919	Torch lead with pigtail, 50' (15.2 m)
5. 075321	Screw, 4-40 x 1/2, Hex, SS (three required)
6. 075322	Screw, 4-40 x 1/4, SL, SZ
7. 028461	On/Off pendant, 25' (7.6 m)
7. 028462	On/Off pendant, 50' (15.2 m)
7. 028463	On/Off pendant, 75' (22.9 m)
8. 044016	O-ring: Buna 90 Duro .614 x .070
4. 128123	Torch lead, 14' (4.3 m) (without pigtail)
4. 128125	Torch lead, 25' (7.6 m) (without pigtail)
4. 128126	Torch lead, 35' (10.7 m) (without pigtail)
4. 128127	Torch lead, 50' (15.2 m) (without pigtail)
023922	Work lead with clamp, 20' (6.1 m)
028907	Work lead with clamp, 50' (15.2 m)

### Assembly – PAC125M machine torch assembly

Part number	Description
083136*	PAC125M torch assembly with pigtail with 14' (4.3 m) leads
083137*	PAC125M torch assembly with pigtail with 25' (7.6 m) leads
083138*	PAC125M torch assembly with pigtail with 35' (10.7 m) leads
083139*	PAC125M torch assembly with pigtail with 50' (15.2 m) leads
083140*	PAC125M torch assembly without pigtail with 14' (4.3 m) leads
083141*	PAC125M torch assembly without pigtail with 25' (7.6 m) leads
083142*	PAC125M torch assembly without pigtail with 35' (10.7 m) leads
083143*	PAC125M torch assembly without pigtail with 50' (15.2 m) leads
083219*	Test torch with 6' (1.8 m) leads
1. 120583	Torch main body with switch
2. 020620	Torch position sleeve
3. 120613	Torch sleeve
4. 129339	Torch lead with pigtail, 15' (4.6 m)
4. 129338	Torch lead with pigtail, 25' (7.6 m)
4. 129340	Torch lead with pigtail, 35' (10.7 m)
4. 129341	Torch lead with pigtail, 50' (15.2 m)
4. 129343	Torch lead without pigtail, 14' (4.3 m)
4. 129342	Torch lead without pigtail, 25' (7.6 m)
4. 129344	Torch lead without pigtail, 35' (10.7 m)
4. 129345	Torch lead without pigtail, 50' (15.2 m)
5. 075321	Screw, 4-40 x 1/2, Hex, SS (three required)
6. 075322	Screw, 4-40 x 1/4, SL, SZ
7. 028714	On/Off pendant, 25' (7.6 m)
7. 128061	On/Off pendant, 50' (15.2 m)
7. 128062	On/Off pendant, 75' (22.9 m)
8. 044016	O-ring: Buna 90 Duro .614 x .070
023922	Work lead with clamp, 20' (6.1 m)
028907	Work lead with clamp, 50' (15.2 m)

\*Assembly includes consumables

