

Hypertherm®

powermax900

PAC125T hand torch consumables



Shielded consumables



	Shield	Retaining cap	Nozzle	Electrode	Swirl ring
55 A	120601	120600	120577	120573	120576

Unshielded* consumables

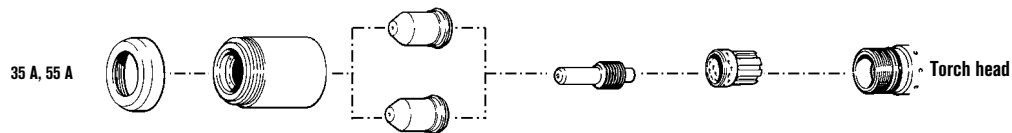

	Deflector	Retaining cap	Nozzle	Electrode	Swirl ring
35 A Pipe saddle	120303	120600	120606	120574	120576
55 A Pipe saddle	120303	120600	120578	120574	120576



Gouging consumables

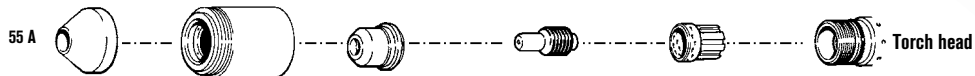

	Shield	Retaining cap	Nozzle	Electrode	Swirl ring
55 A	120608	120600	120607	120573	120576



FineCut consumables

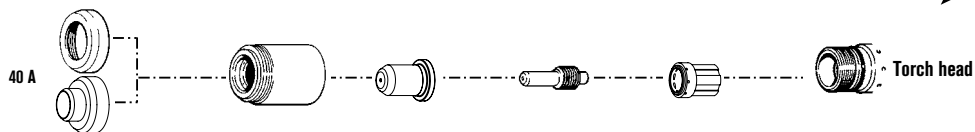

	Deflector	Retaining cap	Nozzle	Electrode	Swirl ring
40 A	120303	120600	220330	120574	220332
40 A CE**	220326	120600	220330	120574	220332

Note:
The nozzles and swirl rings shown must be used as a set.

* In countries following CE standards, unshielded consumables may only be used in mechanized torch applications.

** CE shield for use in countries requiring CE, CCC, GOST marks.

Hypertherm, Powermax, PAC, FineCut and HyLife are trademarks of Hypertherm, Inc. and may be registered in the United States and/or other countries.

TECHNOLOGIES

FineCut®
Spiral groove
Vented shield
HyLife®

powermax900

PAC125T hand torch assembly

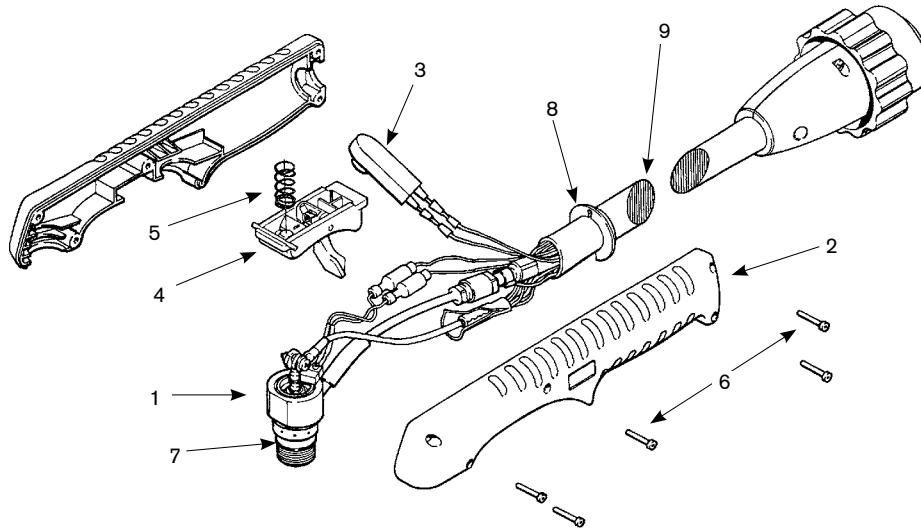

Assembly

Part number	Description
083066*	PAC125T hand torch assembly with 25' (7.6 m) leads
083067*	PAC125T hand torch assembly with 50' (15.2 m) leads
083219*	Test torch with 6' (1.8 m) leads
1. 120570	Torch main body with switch
2. 001288	Handle (includes both halves)
3. 128284	Kit: Switch repair
4. 002244	Safety trigger assembly
5. 027254	Trigger spring
6. 075339	Screw, #4 x 1/2" (five required)
7. 044016	O-ring, Buna – N 90 Duro
8. 004764	Ring, Gutcha
9. 129352	PAC125T torch leads, 25' (7.6 m)
9. 129353	PAC125T torch leads, 50' (15.2 m)
023922	Work lead with clamp, 20' (6.1 m)
028907	Work lead with clamp, 50' (15.2 m)

*Assembly includes consumables



Hypertherm®

powermax900

PAC125M machine torch consumables



Shielded consumables

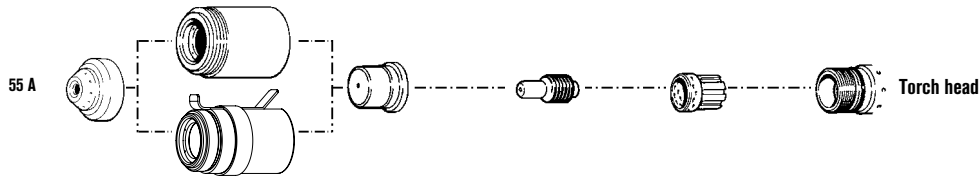

	Shield	Retaining cap	Nozzle	Electrode	Swirl ring
55 A	120602	120600	120577	120573	120576
Ohmic		120964			

Unshielded consumables

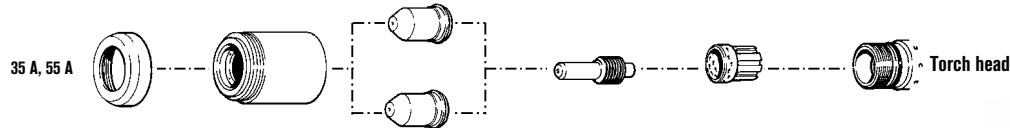

	Deflector	Retaining cap	Nozzle	Electrode	Swirl ring
35 A Pipe saddle	120303	120600	120606	120574	120576
55 A Pipe saddle	120303	120600	120578	120574	120576

Gouging consumables

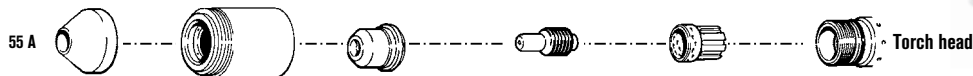

	Shield	Retaining cap	Nozzle	Electrode	Swirl ring
55 A	120608	120600	120607	120573	120576

FineCut consumables

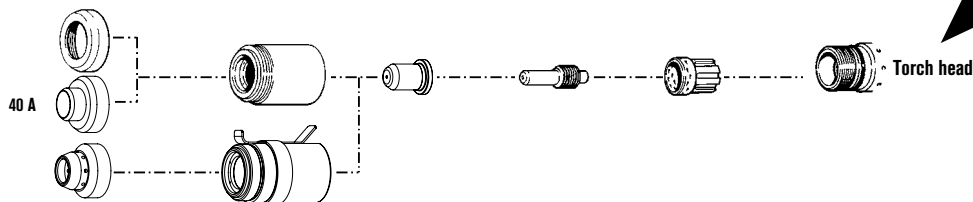

	Shield / Deflector	Retaining cap	Nozzle	Electrode	Swirl ring
40 A	120303	120600	220330	120574	120576
40 A CE	220326	120600	220330	120574	120576
Ohmic	220403	120964			



For improved performance, retrofit with the RT60M torch [see page 77].

Note:
The nozzles and swirl rings shown must be used as a set.

TECHNOLOGIES
FineCut®
Spiral groove
Vented shield
HyLife®

Hypertherm, Powermax, PAC, FineCut and HyLife are trademarks of Hypertherm, Inc. and may be registered in the United States and/or other countries.

PAC125M machine torch assembly

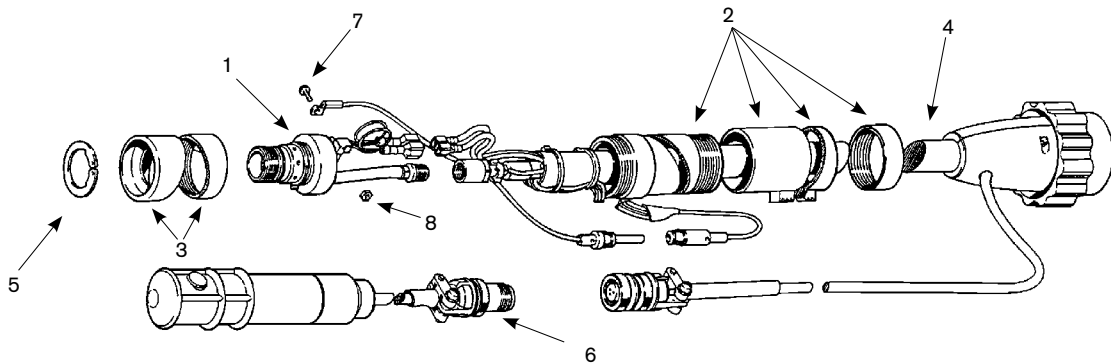

Assembly

Part number	Description
083069*	PAC125M torch assembly with pigtail with 14' (4.3 m) leads
083068*	PAC125M torch assembly with pigtail with 25' (7.6 m) leads
083070*	PAC125M torch assembly with pigtail with 35' (10.7 m) leads
083071*	PAC125M torch assembly with pigtail with 50' (15.2 m) leads
083073*	PAC125M torch assembly without pigtail with 14' (4.3 m)
083072*	PAC125M torch assembly without pigtail with 25' (7.6 m)
083074*	PAC125M torch assembly without pigtail with 35' (10.7 m)
083075*	PAC125M torch assembly without pigtail with 50' (15.2 m)
083219*	Test torch with 6' (1.8 m) leads
1. 120583	Torch main body with switch
2. 020620	Torch position sleeve
3. 120613	Torch sleeve
4. 129339	Torch lead with pigtail, 14' (4.3 m)
4. 129338	Torch lead with pigtail, 25' (7.6 m)
4. 129340	Torch lead with pigtail, 35' (10.7 m)
4. 129341	Torch lead with pigtail, 50' (15.2 m)
5. 027599	Snap ring
6. 028714	On/Off pendant, 25' (7.6 m)
6. 128061	On/Off pendant, 50' (15.2 m)
6. 128062	On/Off pendant, 75' (22.9 m)
7. 075504	Screw, 4-40 x 5/16"
8. 075503	Locknut, 4-40
4. 129343	Torch lead without pigtail, 14' (4.3 m)
4. 129342	Torch lead without pigtail, 25' (7.6 m)
4. 129344	Torch lead without pigtail, 35' (10.7 m)
4. 129345	Torch lead without pigtail, 50' (15.2 m)
023922	Work lead with clamp, 20' (6.1 m)
028907	Work lead with clamp, 50' (15.2 m)

*Assembly includes consumables

